

DIMENSIONS

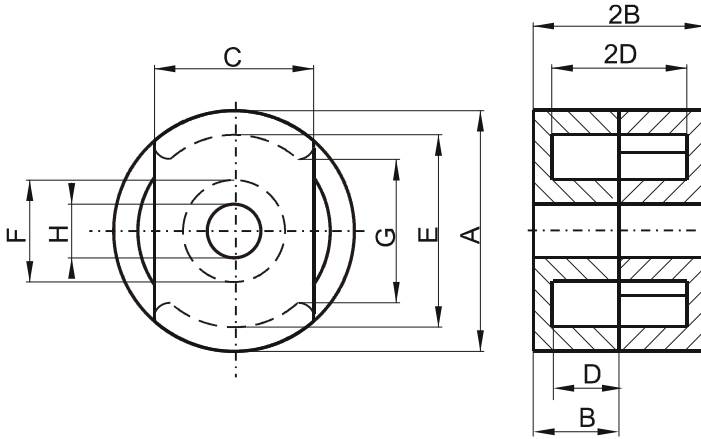

(mm)	Nominal:	Tol. min.:	Tol. max.:
A	22.9	-0.45	+ 0.45
B	9.0	-0.18	+ 0.18
2B	18.0	-0.35	+ 0.35
C	15.25	-0.25	+ 0.25
D	7.2	-0.18	+ 0.18
2D	14.4	-0.35	+ 0.35
E	18.3	-0.35	+ 0.35
F	9.7	-0.2	+ 0.2
G	13.2 Min.		
H	5.1	-0.1	+ 0.1
Eff. Parameters			
Ae mm²	Amin mm²	le mm	Ve mm³
62.2	53.6	41.6	2590

INDUCTANCE

AL value (nH)	Test conditions
Nom: 3066 Min.: 2300	10 kHz, < 0.5 mT, 25 °C

MARKING

R UG

CORE LOSSES

P _i max	Test conditions
100 mW/cm ³ (0.26 W/set)	100 kHz, 100 mT, 100 °C
579 mW/cm ³ (1.5 W/set)	100 kHz, 200 mT, 100 °C

NOTE

Spec. modifications	Previous	Revised
2005-06-22	A=23.32 Max. B=8.84 Min. 2B=17.68 Min. H=5.08±0.1 Losses: General R material	A=23.35 Max. B=8.82 Min. 2B=17.65 Min. H=5.1±0.1 Losses: Detail as indicated