

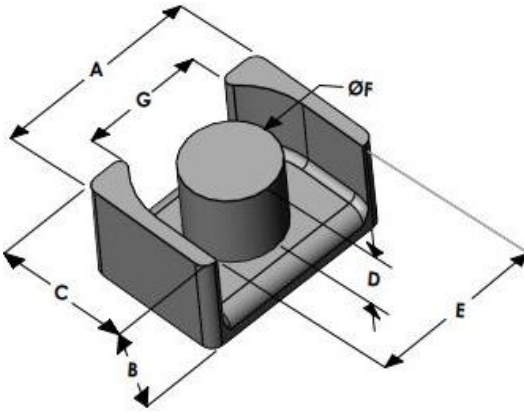

# LPX4225E040L123

110 Delta Drive  
 Pittsburgh, PA 15238  
 NAFTA Sales: (1)800-245-3984  
 HK Sales : (852)3102-9337  
 magnetics@spang.com  
 www.mag-inc.com



XFlux Permeability ( $\mu$ )	$A_L$ (nH/T <sup>2</sup> )	Core Marking	
		Lot Number	Part Number
40	156 ± 8%	XXXXXX	LPX4225E040L123

	Dimensions		Tolerance (±)		Packaging
	(mm)	(in)	(mm)	(in)	
A	42.00	1.653	0.50	0.020	Est. Box Qty= 180 Pcs
B	12.30	0.484	0.20	0.008	
C	25.00	0.984	0.30	0.012	
D	7.90	0.311	0.20	0.008	Available Hardware
E	35.20	1.385	0.40	0.016	
F	16.20	0.638	0.30	0.012	
G	27.25	1.072	0.35	0.014	

Electrical Characteristics			Physical Characteristics					
Watt Loss @ 50kHz, 100mT max (mW/cm <sup>3</sup> )	DC Bias min (oersteds)		Break Strength typ (kg)	Window Area $W_a$ (mm <sup>2</sup> )	Cross Section $A_e$ (mm <sup>2</sup> )	Path Length $L_e$ (mm)	Volume $V_e$ (mm <sup>3</sup> )	Est. Weight (Ea. Piece) (g)
	80%	50%						
550	100	190	73	150	206	76.1	15,680	47.47

Note: Standard AL is controlled with full window high turns test coils. Application coils with few turns often result in lower inductance than expected, or sometimes higher.

Notes:	Temperature Rating
	Curie Temp: 700 °C

