

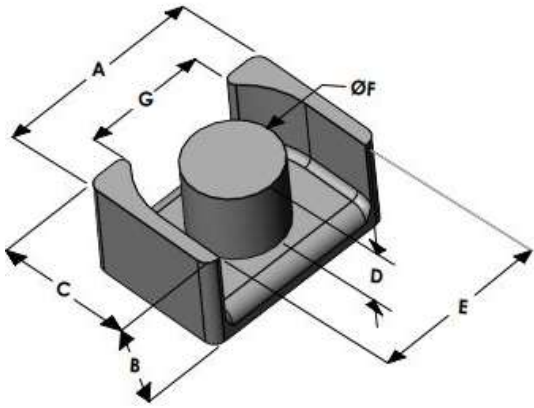

LPX3020E040L118

110 Delta Drive
 Pittsburgh, PA 15238
 NAFTA Sales: (1)800-245-3984
 HK Sales : (852)3102-9337
 magnetics@spang.com
 www.mag-inc.com



XFlux Permeability (μ)	A_L (nH/T ²)	Core Marking	
		Lot Number	Part Number
40	96 ± 8%	XXXXXX	LPX3020E040L118

	Dimensions		Tolerance (±)		Packaging
	(mm)	(in)	(mm)	(in)	
A	30.00	1.181	0.40	0.016	Box Qty= 300 Pcs
B	11.80	0.464	0.20	0.008	
C	20.00	0.787	0.30	0.012	
D	8.50	0.335	0.20	0.008	Available Hardware
E	25.60	1.007	0.30	0.012	
F	12.00	0.472	0.20	0.008	
G					

Electrical Characteristics			Physical Characteristics					
Watt Loss @ 50kHz, 100mT max (mW/cm ³)	DC Bias min (oersteds)		Break Strength typ (kg)	Window Area W_a (mm ²)	Cross Section A_c (mm ²)	Path Length L_e (mm)	Volume V_e (mm ³)	Est. Weight (Ea. Piece) (g)
550	80%	50%	23	116	114	68.5	7,800	TBD
	100	190						

Note: Standard AL is controlled with full window high turns test coils. Application coils with few turns often result in lower inductance than expected, or sometimes higher.

Notes:	Temperature Rating
	Curie Temp: 700 °C

