

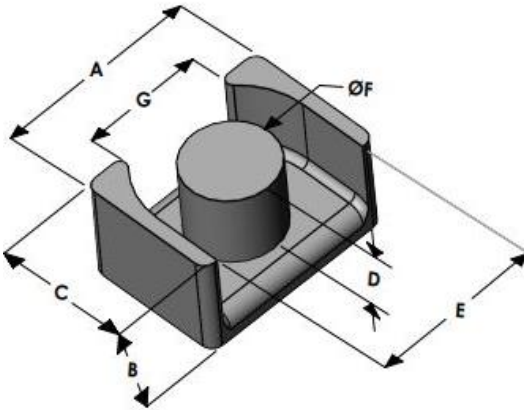

LPX2314E075L087

110 Delta Drive
 Pittsburgh, PA 15238
 NAFTA Sales: (1)800-245-3984
 HK Sales : (852)3102-9337
 magnetics@spang.com
 www.mag-inc.com



XFlux Permeability (μ)	A_L (nH/T ²)	Core Marking	
		Lot Number	Part Number
75	134 ± 8%	XXXXXX	LPX2314E075L087

	Dimensions		Tolerance (±)		Packaging
	(mm)	(in)	(mm)	(in)	
A	23.39	0.921	0.30	0.012	Est. Box Qty= 630 Pcs
B	8.71	0.343	0.20	0.008	
C	14.00	0.551	0.20	0.008	
D	6.20	0.244	0.20	0.008	Available Hardware
E	19.41	0.764	0.20	0.008	
F	9.19	0.362	0.20	0.008	
G					

Electrical Characteristics			Physical Characteristics					
Watt Loss @ 50kHz, 100mT max (mW/cm ³)	DC Bias min (oersteds)		Break Strength typ (kg)	Window Area W_a (mm ²)	Cross Section A_e (mm ²)	Path Length L_e (mm)	Volume V_e (mm ³)	Est. Weight (Ea. Piece) (g)
	80%	50%						
700	65	110	27	63.4	67.0	49.1	3,290	TBD

Note: Standard AL is controlled with full window high turns test coils. Application coils with few turns often result in lower inductance than expected, or sometimes higher.

Notes:	Temperature Rating
	Curie Temp: 700 °C

