

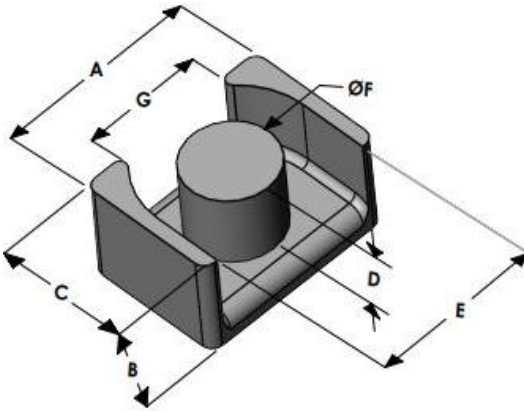

# LPH3624E060L144

110 Delta Drive  
 Pittsburgh, PA 15238  
 NAFTA Sales: (1)800-245-3984  
 HK Sales : (852)3102-9337  
 magnetics@spang.com  
 www.mag-inc.com



High Flux Permeability ( $\mu$ )	$A_L$ (nH/T <sup>2</sup> )	Core Marking	
		Lot Number	Part Number
60	177 ± 8%	XXXXXX	LPH3624E060L144

	Dimensions		Tolerance (±)		Packaging
	(mm)	(in)	(mm)	(in)	
A	36.20	1.425	0.40	0.016	Est. Box Qty= 240 Pcs
B	14.40	0.567	0.20	0.008	
C	24.00	0.945	0.30	0.012	
D	10.40	0.409	0.20	0.008	Available Hardware
E	30.40	1.196	0.40	0.016	
F	15.00	0.590	0.20	0.008	
G	22.28	0.877	0.30	0.012	

Electrical Characteristics			Physical Characteristics					
Watt Loss @ 100 kHz, 100mT max (mW/cm <sup>3</sup> )	DC Bias min (oersteds)		Break Strength typ (kg)	Window Area $W_a$ (mm <sup>2</sup> )	Cross Section $A_e$ (mm <sup>2</sup> )	Path Length $L_e$ (mm)	Volume $V_e$ (mm <sup>3</sup> )	Est. Weight (Ea. Piece) (g)
	80%	50%						
850	85	140	66	160	177	80.6	14,270	48.99

Note: Standard AL is controlled with full window high turns test coils. Application coils with few turns often result in lower inductance than expected, or sometimes higher.

Notes:	Temperature Rating
	Curie Temp: 500 °C

