

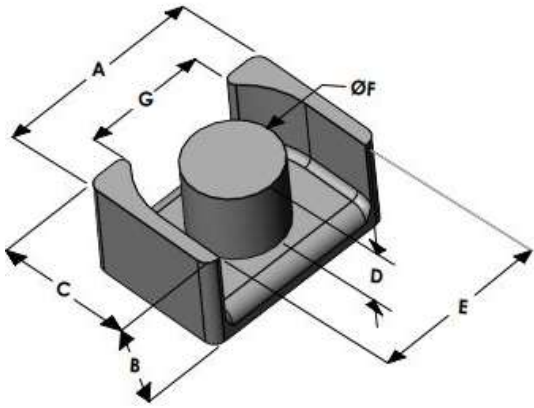

LPH3222E026L152

110 Delta Drive
 Pittsburgh, PA 15238
 NAFTA Sales: (1)800-245-3984
 HK Sales : (852)3102-9337
 magnetics@spang.com
 www.mag-inc.com



High Flux Permeability (μ)	A_L (nH/T ²)	Core Marking	
		Lot Number	Part Number
26	69 ± 8%	XXXXXX	LPH3222E026L152

	Dimensions		Tolerance (±)			Packaging
	(mm)	(in)	(mm)	(in)		
A	32.00	1.259	0.40	0.016		Box Qty= 300 Pcs
B	15.20	0.598	0.20	0.008		
C	22.00	0.866	0.30	0.012		
D	11.50	0.453	0.20	0.008		Available Hardware
E	27.00	1.063	0.30	0.012		
F	13.50	0.531	0.20	0.008		
G	20.43	0.804	-	-	Min	

Electrical Characteristics			Physical Characteristics					
Watt Loss @ 100 kHz, 100mT max (mW/cm ³)	DC Bias min (oersteds)		Break Strength typ (kg)	Window Area W_a (mm ²)	Cross Section A_c (mm ²)	Path Length L_e (mm)	Volume V_e (mm ³)	Est. Weight (Ea. Piece) (g)
	80%	50%						
850	190	320	45	155	143	82.1	11,740	TBD

Note: Standard AL is controlled with full window high turns test coils. Application coils with few turns often result in lower inductance than expected, or sometimes higher.

Notes:	Temperature Rating
	Curie Temp: 500 °C

Typical DC Bias Performance

