

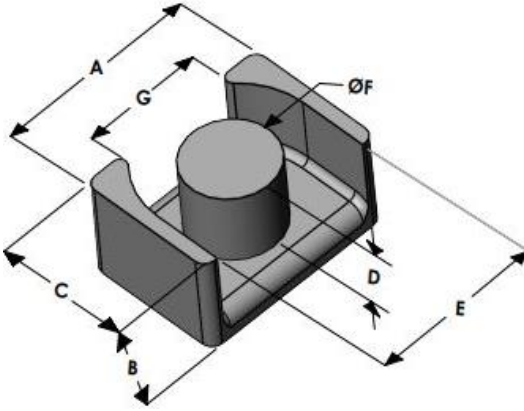

LPH2518E060L099

110 Delta Drive
 Pittsburgh, PA 15238
 NAFTA Sales: (1)800-245-3984
 HK Sales : (852)3102-9337
 magnetics@spang.com
 www.mag-inc.com



High Flux Permeability (μ)	A_L (nH/T ²)	Core Marking	
		Lot Number	Part Number
60	139 ± 8%	XXXXXX	LPH2518E060L099

	Dimensions		Tolerance (±)		Packaging
	(mm)	(in)	(mm)	(in)	
A	25.00	0.984	0.30	0.012	Est. Box Qty= 588 Pcs
B	9.90	0.390	0.20	0.008	
C	18.00	0.708	0.20	0.008	
D	6.90	0.272	0.20	0.008	Available Hardware
E	21.00	0.826	0.30	0.012	
F	11.00	0.433	0.20	0.008	
G	14.21	0.559	0.30	0.012	

Electrical Characteristics			Physical Characteristics					
Watt Loss @ 100 kHz, 100mT max (mW/cm ³)	DC Bias min (oersteds)		Break Strength typ (kg)	Window Area W_a (mm ²)	Cross Section A_e (mm ²)	Path Length L_e (mm)	Volume V_e (mm ³)	Est. Weight (Ea. Piece) (g)
	80%	50%						
850	85	140	41	69.0	96.0	55.7	5,350	18.27

Note: Standard AL is controlled with full window high turns test coils. Application coils with few turns often result in lower inductance than expected, or sometimes higher.

Notes:	Temperature Rating
	Curie Temp: 500 °C

