

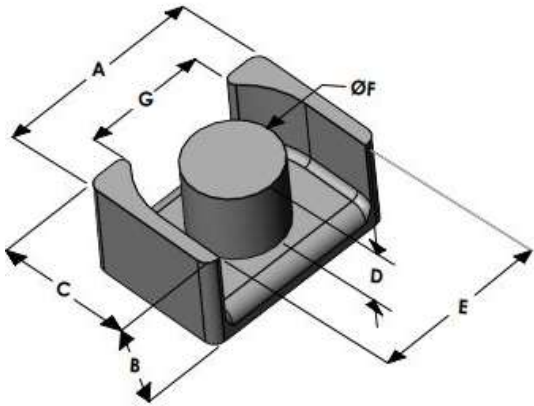

# LPH2518E026L099

110 Delta Drive  
 Pittsburgh, PA 15238  
 NAFTA Sales: (1)800-245-3984  
 HK Sales : (852)3102-9337  
 magnetics@spang.com  
 www.mag-inc.com



High Flux Permeability ( $\mu$ )	$A_L$ (nH/T <sup>2</sup> )	Core Marking	
		Lot Number	Part Number
26	68 ± 8%	XXXXXX	LPH2518E026L099

	Dimensions		Tolerance (±)		Packaging
	(mm)	(in)	(mm)	(in)	
A	25.00	0.984	0.30	0.012	Box Qty= 588 Pcs
B	9.90	0.390	0.20	0.008	
C	18.00	0.708	0.20	0.008	
D	6.90	0.272	0.20	0.008	Available Hardware
E	21.00	0.826	0.30	0.012	
F	11.00	0.433	0.20	0.008	
G	14.21	0.559	0.30	0.012	

Electrical Characteristics			Physical Characteristics					
Watt Loss @ 100 kHz, 100mT max (mW/cm <sup>3</sup> )	DC Bias min (oersteds)		Break Strength typ (kg)	Window Area W <sub>a</sub> (mm <sup>2</sup> )	Cross Section A <sub>c</sub> (mm <sup>2</sup> )	Path Length L <sub>e</sub> (mm)	Volume V <sub>e</sub> (mm <sup>3</sup> )	Est. Weight (Ea. Piece) (g)
850	80%	50%	27	69.0	96.0	55.7	5,350	TBD
	190	320						

Note: Standard AL is controlled with full window high turns test coils. Application coils with few turns often result in lower inductance than expected, or sometimes higher.

Notes:	Temperature Rating
	Curie Temp: 500 °C

