

Specification for:

HR42311UG

110 Delta Drive
Pittsburgh, PA 15238
Phone: 412/696-1333
Fax: 412/696-0333
Email: magnetics@spang.com

DIMENSIONS

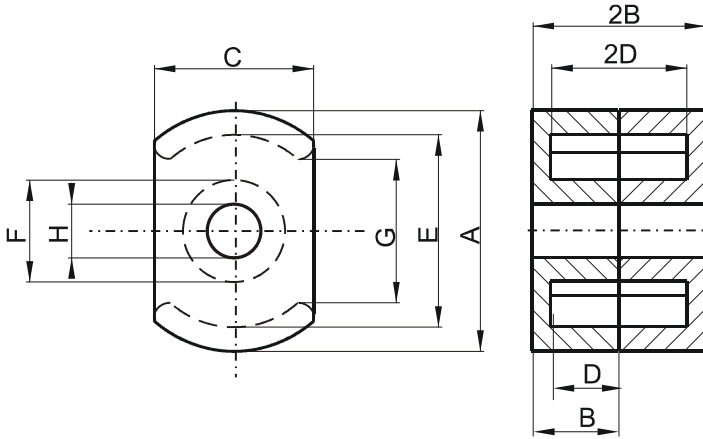

(mm)	Nominal:	Tol. min.:	Tol. max.:
A	22.86	-0.46	+ 0.46
B	5.54	-0.13	+ 0.13
2B	11.08	-0.26	+ 0.26
C	15.24	-0.25	+ 0.25
D	3.63 Min.		
2D	7.26 Min.		
E	17.93 Min.		
F	9.9 Max.		
G	13.21 Min.		
H	5.1	-0.1	+ 0.1
Eff. Parameters			
Ae mm²	Amin mm²	le mm	Ve mm³
48.2	37.8	27.0	1300

INDUCTANCE

AL value (nH)	Test conditions
Nom: 3200 Min.: 2400	10 kHz, < 0.5 mT, 25 °C

MARKING

R UG

CORE LOSSES

P _i max	Test conditions
100 mW/cm ³ (0.13 W/set)	100 kHz, 100 mT, 100 °C
615 mW/cm ³ (0.8 W/set)	100 kHz, 200 mT, 100 °C

NOTE

Spec. modifications	Previous	Revised
2005-06-22	H=5.08±0.1 Losses: General R material	H=5.1±0.1 Losses: Detail as indicated