

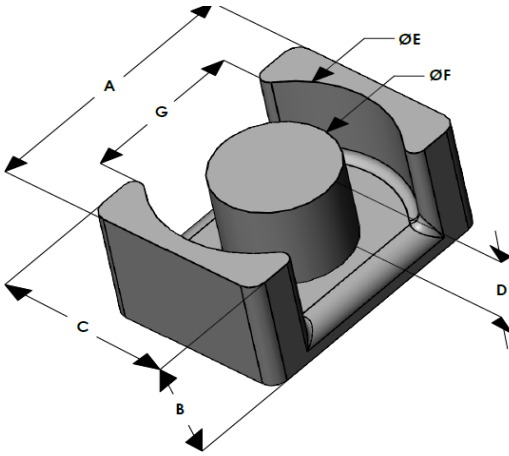

# EQX2619E026L088

110 Delta Drive  
 Pittsburgh, PA 15238  
 NAFTA Sales: (1)800-245-3984  
 HK Sales : (852)3102-9337  
 magnetics@spang.com  
 www.mag-inc.com



XFlux Permeability ( $\mu$ )	$A_L$ (nH/T <sup>2</sup> )	Core Marking	
		Lot Number	Part Number
26	95 ± 8%	XXXXXX	EQX2619E026L088

	Dimensions		Tolerance (±)			Packaging
	(mm)	(in)	(mm)	(in)		
A	26.50	1.043	0.30	0.012		Est. Box Qty= 250 Pcs
B	8.79	0.346	0.20	0.008		
C	19.00	0.748	0.20	0.008		
D	5.49	0.216	0.20	0.008		Available Hardware
E	22.60	0.889	0.20	0.008		
F	12.00	0.472	0.20	0.008		
G	15.00	0.590	-	-	Min	

Electrical Characteristics			Physical Characteristics					
Watt Loss @ 50kHz, 100mT max (mW/cm <sup>3</sup> )	DC Bias min (oersteds)		Break Strength typ (kg)	Window Area W <sub>a</sub> (mm <sup>2</sup> )	Cross Section A <sub>e</sub> (mm <sup>2</sup> )	Path Length L <sub>e</sub> (mm)	Volume V <sub>e</sub> (mm <sup>3</sup> )	Est. Weight (Ea. Piece) (g)
	80%	50%						
425	140	250	50	58.2	120	49.5	5,834	16.55

Note: Standard AL is controlled with full window high turns test coils. Application coils with few turns often result in lower inductance than expected, or sometimes higher.

Notes:	Temperature Rating
	Curie Temp: 700 °C

