

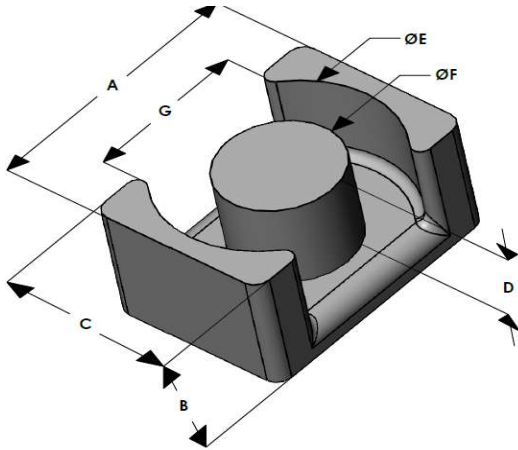

EQH3626E060L100

110 Delta Drive
 Pittsburgh, PA 15238
 NAFTA Sales: (1)800-245-3984
 HK Sales : (852)3102-9337
 magnetics@spang.com
 www.mag-inc.com



| High Flux Permeability (μ) | A_L (nH/T ²) | Core Marking | |
|----------------------------------|----------------------------|--------------|-----------------|
| | | Lot Number | Part Number |
| 60 | 224 ± 8% | XXXXXX | EQH3626E060L100 |

| | Dimensions | | Tolerance (±) | | Packaging | |
|----------|------------|-------|---------------|-------|------------------|--------------------|
| | (mm) | (in) | (mm) | (in) | | |
| A | 36.00 | 1.417 | 0.40 | 0.016 | Box Qty= 210 Pcs | |
| B | 10.00 | 0.394 | 0.20 | 0.008 | | |
| C | 26.00 | 1.023 | 0.30 | 0.012 | | |
| D | 6.00 | 0.236 | - | - | Nom | Available Hardware |
| E | 32.00 | 1.259 | 0.30 | 0.012 | | |
| F | 14.40 | 0.567 | 0.20 | 0.008 | | |
| G | 22.30 | 0.878 | 0.30 | 0.012 | | |

| Electrical Characteristics | | | Physical Characteristics | | | | | |
|--|------------------------|-----|--------------------------|--------------------------------------|--|------------------------|---------------------------------|-----------------------------|
| Watt Loss @ 100 kHz, 100mT max (mW/cm ³) | DC Bias min (oersteds) | | Break Strength typ (kg) | Window Area W_a (mm ²) | Cross Section A_c (mm ²) | Path Length L_e (mm) | Volume V_e (mm ³) | Est. Weight (Ea. Piece) (g) |
| | 80% | 50% | | | | | | |
| 850 | 85 | 140 | 32 | 106 | 181 | 65.1 | 11,800 | TBD |

Note: Standard AL is controlled with full window high turns test coils. Application coils with few turns often result in lower inductance than expected, or sometimes higher.

| Notes: | Temperature Rating |
|--------|--------------------|
| | Curie Temp: 500 °C |

