

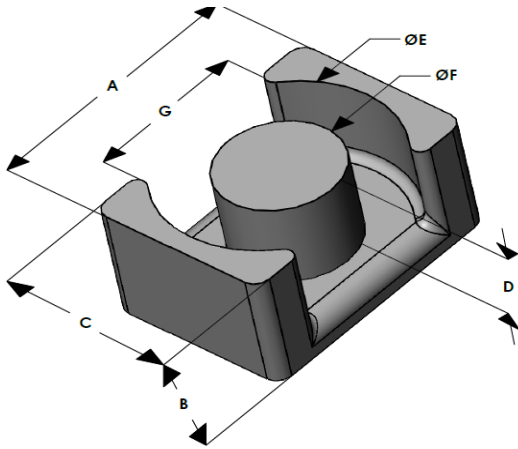

EQG3222E040L152

110 Delta Drive
 Pittsburgh, PA 15238
 NAFTA Sales: (1)800-245-3984
 HK Sales : (852)3102-9337
 magnetics@spang.com
 www.mag-inc.com



Edge Permeability (μ)	A_L (nH/T ²)	Core Marking	
		Lot Number	Part Number
40	110 ± 8%	XXXXXX	EQG3222E040L152

	Dimensions		Tolerance (±)		Packaging
	(mm)	(in)	(mm)	(in)	
A	32.00	1.259	0.30	0.012	Est. Box Qty= 300 Pcs
B	15.20	0.598	0.20	0.008	
C	22.00	0.866	0.30	0.012	
D	11.50	0.453	0.20	0.008	Available Hardware
E	27.60	1.086	0.30	0.012	
F	13.50	0.531	0.20	0.008	
G	20.43	0.804	-	-	Min

Electrical Characteristics		Physical Characteristics						
Watt Loss @ 100 kHz, 100mT max (mW/cm ³)	DC Bias min (oersteds)		Break Strength typ (kg)	Window Area W_a (mm ²)	Cross Section A_e (mm ²)	Path Length L_e (mm)	Volume V_e (mm ³)	Est. Weight (Ea. Piece) (g)
	80%	50%						
550	140	215	45	162	152	79.9	12,168	TBD

Note: Standard AL is controlled with full window high turns test coils. Application coils with few turns often result in lower inductance than expected, or sometimes higher.

Notes:	Temperature Rating
	Curie Temp: 500 °C

Typical DC Bias Performance

