

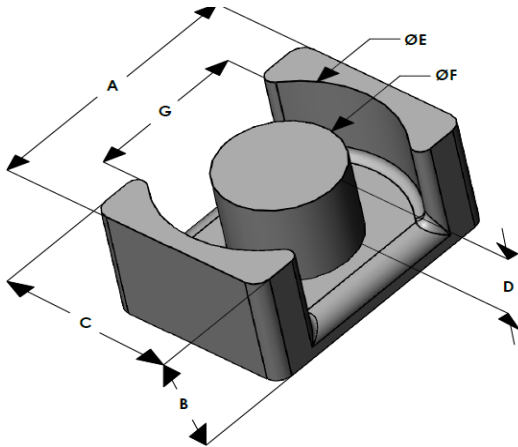

# EQG2619E060L070

110 Delta Drive  
 Pittsburgh, PA 15238  
 NAFTA Sales: (1)800-245-3984  
 HK Sales : (852)3102-9337  
 magnetics@spang.com  
 www.mag-inc.com



| Edge Permeability ( $\mu$ ) | $A_L$ (nH/T <sup>2</sup> ) | Core Marking |                 |
|-----------------------------|----------------------------|--------------|-----------------|
|                             |                            | Lot Number   | Part Number     |
| 60                          | 228 ± 8%                   | XXXXXX       | EQG2619E060L070 |

|          | Dimensions |       | Tolerance (±) |       | Packaging                 |
|----------|------------|-------|---------------|-------|---------------------------|
|          | (mm)       | (in)  | (mm)          | (in)  |                           |
| <b>A</b> | 26.50      | 1.043 | 0.30          | 0.012 | Est. Box Qty= 250 Pcs     |
| <b>B</b> | 7.00       | 0.275 | 0.15          | 0.006 |                           |
| <b>C</b> | 19.00      | 0.748 | 0.20          | 0.008 |                           |
| <b>D</b> | 3.70       | 0.146 | 0.15          | 0.006 | <b>Available Hardware</b> |
| <b>E</b> | 22.60      | 0.889 | 0.20          | 0.008 |                           |
| <b>F</b> | 12.00      | 0.472 | 0.20          | 0.008 |                           |
| <b>G</b> | 15.00      | 0.590 | -             | -     | <b>Min</b>                |

| Electrical Characteristics                           |                        |     | Physical Characteristics |                                      |  |                        |                                 |                             |
|--|------------------------|-----|--------------------------|--------------------------------------|--|------------------------|---------------------------------|-----------------------------|
| Watt Loss @ 100 kHz, 100mT max (mW/cm <sup>3</sup> ) | DC Bias min (oersteds) |     | Break Strength typ (kg)  | Window Area $W_a$ (mm <sup>2</sup> ) | Cross Section $A_e$ (mm <sup>2</sup> ) | Path Length $L_e$ (mm) | Volume $V_e$ (mm <sup>3</sup> ) | Est. Weight (Ea. Piece) (g) |
|  | 80%                    | 50% |                          |                                      |  |                        |                                 |                             |
| 550  | 105                    | 160 | 34                       | 39.2                                 | 120                                    | 42.3                   | 5,070                           | TBD                         |

Note: Standard AL is controlled with full window high turns test coils. Application coils with few turns often result in lower inductance than expected, or sometimes higher.

| Notes: | Temperature Rating |
|--------|--------------------|
|        | Curie Temp: 500 °C |

## Typical DC Bias Performance

