

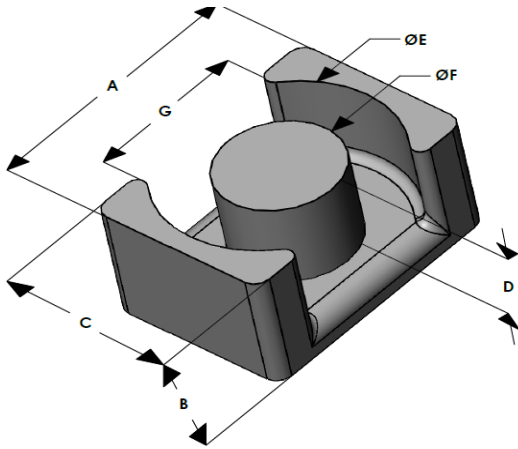

EQG2619E040L070

110 Delta Drive
 Pittsburgh, PA 15238
 NAFTA Sales: (1)800-245-3984
 HK Sales : (852)3102-9337
 magnetics@spang.com
 www.mag-inc.com



Edge Permeability (μ)	A_L (nH/T ²)	Core Marking	
		Lot Number	Part Number
40	164 ± 8%	XXXXXX	EQG2619E040L070

	Dimensions		Tolerance (±)			Packaging
	(mm)	(in)	(mm)	(in)		
A	26.50	1.043	0.30	0.012		Est. Box Qty= 250 Pcs
B	7.00	0.275	0.15	0.006		
C	19.00	0.748	0.20	0.008		
D	3.70	0.146	0.15	0.006		Available Hardware
E	22.60	0.889	0.20	0.008		
F	12.00	0.472	0.20	0.008		
G	15.00	0.590	-	-	Min	

Electrical Characteristics			Physical Characteristics					
Watt Loss @ 100 kHz, 100mT max (mW/cm ³)	DC Bias min (oersteds)		Break Strength typ (kg)	Window Area W_a (mm ²)	Cross Section A_e (mm ²)	Path Length L_e (mm)	Volume V_e (mm ³)	Est. Weight (Ea. Piece) (g)
550	80%	50%	34	39.2	120	42.3	5,070	TBD
	140	215						

Note: Standard AL is controlled with full window high turns test coils. Application coils with few turns often result in lower inductance than expected, or sometimes higher.

Notes:	Temperature Rating
	Curie Temp: 500 °C

Typical DC Bias Performance

