

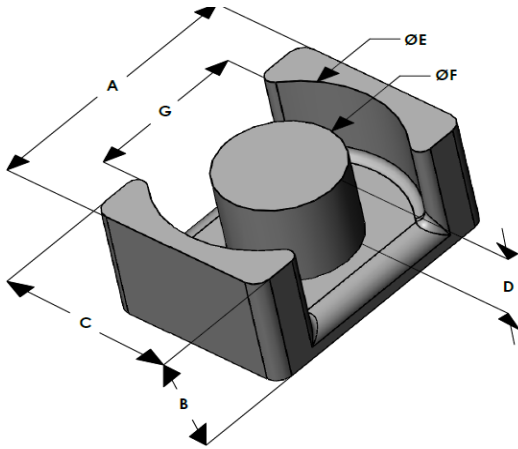

EQG2014E040L061

110 Delta Drive
 Pittsburgh, PA 15238
 NAFTA Sales: (1)800-245-3984
 HK Sales : (852)3102-9337
 magnetics@spang.com
 www.mag-inc.com



Edge Permeability (μ)	A_L (nH/T ²)	Core Marking	
		Lot Number	Part Number
40	98 ± 8%	XXXXXX	EQG2014E040L061

	Dimensions		Tolerance (±)			Packaging
	(mm)	(in)	(mm)	(in)		
A	20.00	0.787	0.30	0.012		Est. Box Qty= 1596 Pcs
B	6.10	0.240	0.20	0.008		
C	14.00	0.551	0.20	0.008		
D	3.70	0.146	0.30	0.012		Available Hardware
E	18.00	0.708	0.20	0.008		
F	8.80	0.346	0.20	0.008		
G	13.00	0.512	-	-	Min	

Electrical Characteristics		Physical Characteristics						
Watt Loss @ 100 kHz, 100mT max (mW/cm ³)	DC Bias min (oersteds)		Break Strength typ (kg)	Window Area W_a (mm ²)	Cross Section A_e (mm ²)	Path Length L_e (mm)	Volume V_e (mm ³)	Est. Weight (Ea. Piece) (g)
550	80%	50%	34	34.1	60.8	35.8	2,180	TBD
	140	215						

Note: Standard AL is controlled with full window high turns test coils. Application coils with few turns often result in lower inductance than expected, or sometimes higher.

Notes:	Temperature Rating
	Curie Temp: 500 °C

Typical DC Bias Performance

