

Specification for:

DF43019UG

110 Delta Drive
Pittsburgh, PA 15238
Phone: 412/696-1333
Fax: 412/696-0333
Email: magnetics@spang.com

DIMENSIONS

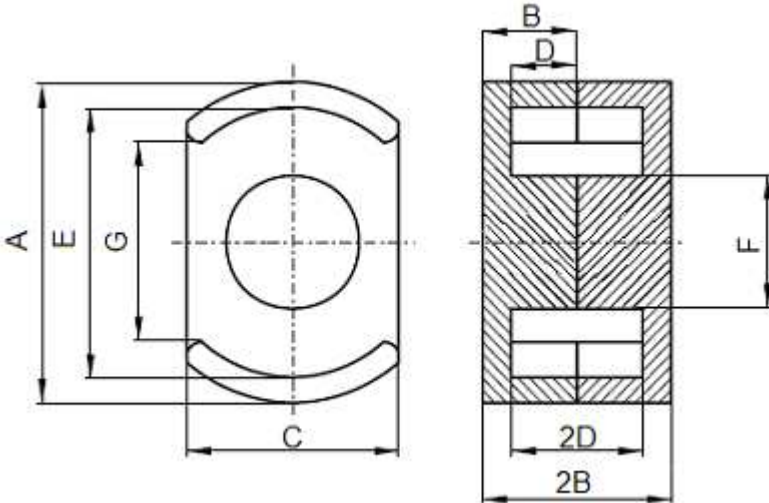

(mm)	Nominal:	Tol. min.:	Tol. max.:
A	30.0	-0.51	+ 0.51
B	9.4	-0.1	+ 0.1
2B	18.8	-0.2	+ 0.2
C	20.32	-0.25	+ 0.25
D	6.5 MIN		
2D	13.0 MIN		
E	25.0 MIN		
F	13.51 MAX		
G	15.49 MIN		
Eff. Parameters			
Ae mm²	Amin mm²	le mm	Ve mm³
117.0	96.0	46.2	5410

INDUCTANCE

AL value (nH)	Test conditions
5800 ± 25%	10 kHz, < 0.5 mT, 25 °C

MARKING

DF43019UG PXXXXX

CORE LOSSES

P _i max	Test conditions
222 mW/cm ³ (1.2 W/set)	25 kHz, 200 mT, 100 °C

NOTE

Spec. modifications	Previous	Revised
2005-06-22	LOSSES:GENERAL F MATERIAL	LOSSES: DETAIL AS INDICATED