

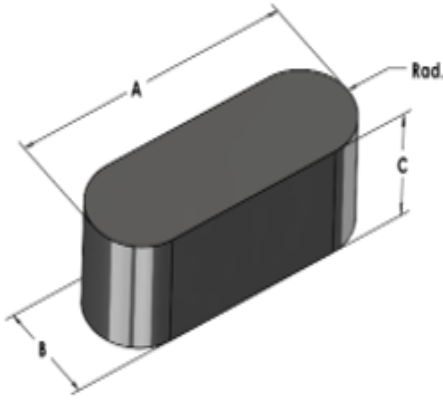

# 00X7528R040

110 Delta Drive  
 Pittsburgh, PA 15238  
 NAFTA Sales: (1)800-245-3984  
 HK Sales : (852)3102-9337  
 magnetics@spang.com  
 www.mag-inc.com



XFlux Permeability ( $\mu$ )	Core Marking	
	Lot Number	Part Number
40	XXXXXX	X7528R040

	Dimensions		Tolerance ( $\pm$ )			Packaging
	(mm)	(in)	(mm)	(in)		
<b>A</b>	74.50	2.933	0.50	0.020		Box Qty = 48
<b>B</b>	27.50	1.083	0.30	0.012		
<b>C</b>	21.70	0.854	0.20	0.008		
<b>Radius</b>	13.75					

Physical Characteristics		Temperature Rating		Note
Volume $V_e$ (mm <sup>3</sup> )	Est. Weight (g)	Curie Temp:	700 °C	Cosmetic Standard: Magnetics Powder Core shapes criteria for appearance
40,900	258			

