

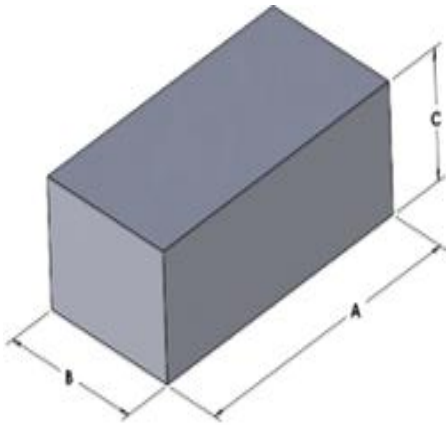

00X6131B040

110 Delta Drive
 Pittsburgh, PA 15238
 NAFTA Sales: (1)800-245-3984
 HK Sales : (852)3102-9337
 magnetics@spang.com
 www.mag-inc.com



XFlux Permeability (μ)	Core Marking	
	Lot Number	Part Number
40	XXXXXX	X6131B040

	Dimensions		Tolerance (\pm)		Packaging
	(mm)	(in)	(mm)	(in)	
A	60.50	2.382	0.50	0.020	Box Qty = 64
B	30.30	1.193	0.30	0.012	
C	20.00	0.787	0.20	0.008	

Physical Characteristics		Temperature Rating		Note
Volume V_e (mm ³)	Est. Weight (g)	Curie Temp:	700 °C	Cosmetic Standard: Magnetics Powder Core shapes criteria for appearance
36,700	231			

